

# CCMC 13690-R

## CCMC Canadian code compliance evaluation

<b>CCMC number:</b>	13690-R
<b>Status:</b>	Active
<b>Issue date:</b>	2014-04-14
<b>Modified date:</b>	2022-05-26
<b>Evaluation holder:</b>	<p><b>Azek Building Products</b></p> <p>888 N. Keyser Ave. Scranton PA 18504 United States Telephone: 570-558-8000</p>
<b>Product name:</b>	AZEK Deck
<b>Code compliance:</b>	NBC 2010, OBC
<b>Evaluation requirements:</b>	CCMC-TG-067315.02-10 "CCMC Technical Guide for Exterior Decking Planks Made of Solid Core PVC Foam Coated with PVC"

**In most jurisdictions this document is sufficient evidence for approval by Canadian authorities.**

[Learn more about CCMC recognition](#)

## Code compliance opinion

It is the opinion of the Canadian Construction Materials Centre that the evaluated product, when used as exterior decking in accordance with the conditions and limitations stated in this evaluation, complies with the following code:

### National Building Code of Canada 2010

Code provision	Solution type
9.3.2.9. Termite and Decay Protection	<u>Alternative</u>
9.4.2.1. Application	<u>Alternative</u>
9.4.2.2. Specified Snow Loads	<u>Acceptable</u>
9.4.2.3. Platforms Subject to Snow and Occupancy Loads	<u>Acceptable</u>
9.4.3.1. Deflections	<u>Alternative</u>
9.8.9.1. Loads on Stairs and Ramps	<u>Acceptable</u>
9.8.9.3. Exterior Wood Steps	<u>Alternative</u>
9.8.9.6. Finish for Treads and Landings	<u>Acceptable</u>
9.23.15.5. Subfloor Thickness or Rating	<u>Alternative</u>

### Ontario Building Code

Ruling No. 15-06-327 (13690-R) authorizing the use of this product in Ontario, subject to the terms and conditions contained in the Ruling, was made by the Minister of Municipal Affairs and Housing on 2015-09-29 pursuant to s.29 of the Building Code Act, 1992 (see Ruling for terms and conditions). This Ruling is subject to periodic revisions and updates.

The above opinion is based on the evaluation by the CCMC of technical evidence provided by the evaluation holder, and is bound by the stated conditions and limitations. For the benefit of the user, a summary of the technical information that forms the basis of this evaluation has been included.

## Product information

### Product name:

AZEK Deck

### Product description

AZEK Deck Harvest mono-extruded deck boards are made from foamed polyvinyl chloride (PVC) and cellulosic fibre with ultraviolet (UV)-resistant additives and colorants. AZEK Deck Arbor, Terra and Harvest co-extruded deck boards are made from PVC and proprietary mineral additives with UV-resistant additives and colorants. The composite products are manufactured through a continuous extrusion/coextrusion process into planks of solid cross-sections of varying thicknesses. Typical board dimensions are 140 mm wide by 25 mm thick.

The product is intended to be used as exterior decking to be installed over traditional structural wood framing.

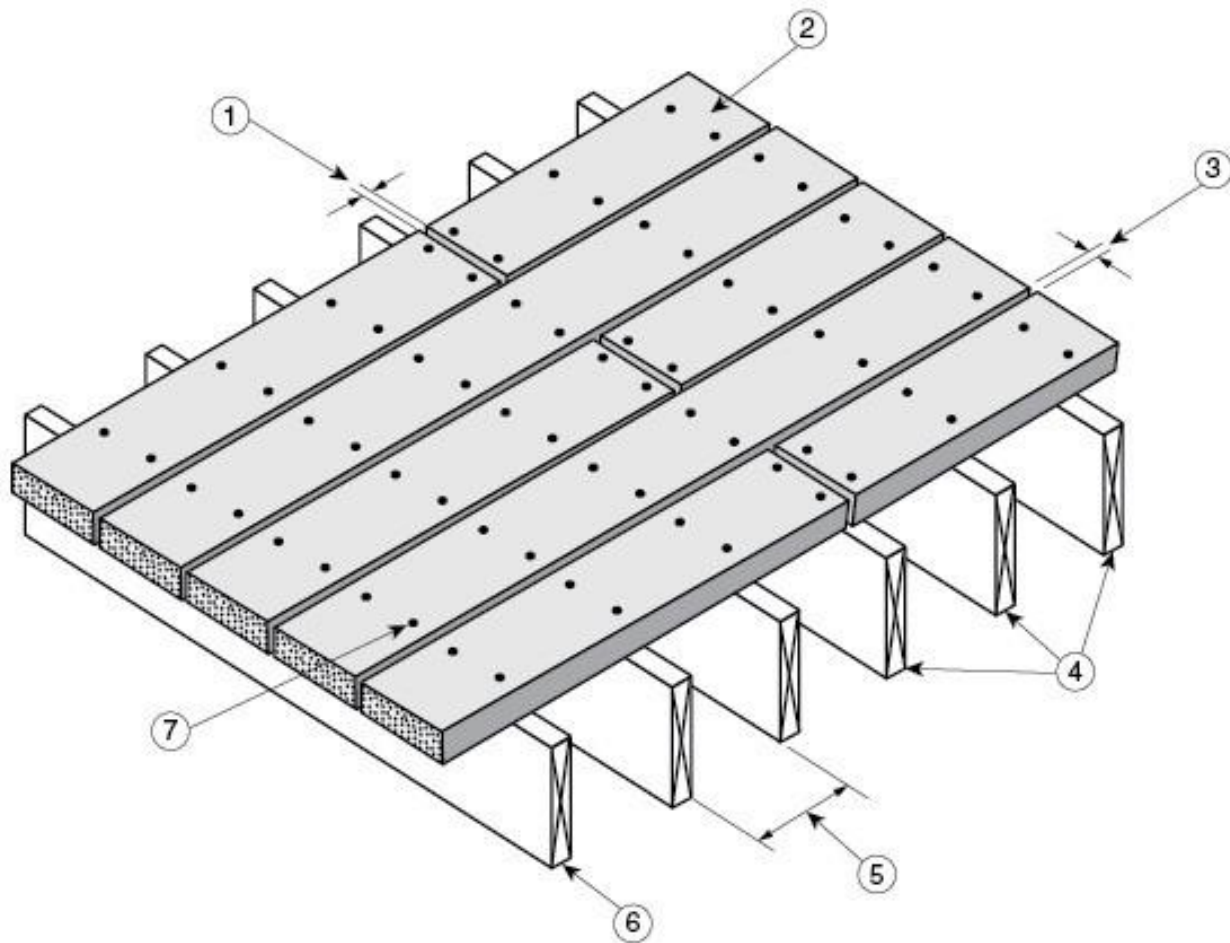

Figure 1. Installation details for the product

1. no gapping necessary
2. AZEK Deck board
3. 3 mm to 6 mm gapping
4. minimum of 3 joists per deck board

5. maximum joist spacing at 400 mm o.c.
6. joist designed to support applicable loads
7. two 57-mm-long fasteners per support

## Manufacturing plants

This evaluation is limited to products produced at the following plants:

Product name	Manufacturing plants	
	Foley, AL, US	Scranton, PA, US
AZEK Deck	◇	◇

◇ Indicates that the product from this manufacturing facility has been evaluated by the CCMC

## Conditions and limitations

The CCMC's compliance opinion is bound by this product being used in accordance with the conditions and limitations set out below.

- The product must be installed with supports spaced no greater than 400 mm on centre (o.c.). Each plank must be supported by at least 3 joists.
- The product must be fastened to the wood joists with fasteners specified by the manufacturer and conforming to Article 9.23.3.1., Standards for Nails and Screws, of Division B of the NBC 2010. The fasteners must have a corrosion protection coating or be made of stainless steel. The planks must be fastened with at least two 57-mm-long fasteners per support. <sup>(1)</sup>
- The width-to-width gapping can vary from 3 mm (0.12 in.) to 6 mm (0.24 in.).
- The product can be used where termite protection is required as per Article 9.3.2.9., Termite and Decay Protection, of Division B of the NBC 2010.
- The product can be used as stair treads at 230 mm (9 in.) o.c. spacing.
- The product is not to be considered as an equivalent to dimensional lumber.

---

### Notes:

- <sup>1</sup> As of January 2004, pressure-treated lumber requires specific hot-dipped galvanized fasteners for satisfactory performance.
-

# Technical information

This evaluation is based on demonstrated conformance with the following criteria:

Criteria number	Criteria name
CCMC-TG-067315.02-10	CCMC Technical Guide for Exterior Decking Planks Made of Solid Core PVC Foam Coated with PVC

## Material requirements

Table 1. Test results for basic physical and mechanical properties

Property		Unit	Requirement	Result (1)	
Dimensional change	coefficient of linear expansion (thermal)	°C <sup>-1</sup>	$< 2 \times 10^{-5}$	$1.69 \times 10^{-6}$	
	coefficient of linear expansion (swelling)	oven-dry to vacuum pressure soak	%	≤ 0.5, by 80% of specimens	0.13
Strength and stiffness	flexural rigidity (EI)	kN·mm <sup>2</sup>	≥ 300 000	Pass	
	moment capacity (Mr)	N·mm	≥ 190 000	Pass	
Creep, recovery and load duration		%	≤ 25 for creep	18	
			≥ 75 for recovery	84	
			No failure	Pass	
Strength and stiffness after aging	weathering	impact resistance	%	≥ 75 of non-weathered value	76%
	accelerated aging	EI	%	≥ 50 of non-aged value	Pass
		Mr			Pass
Fastener holding capacity		nail withdrawal strength	N	≥ 600	2626
		lateral nail strength	N	≥ 720	1416
Flame-spread rating		–	≤ 200	25	

### Note

1 Test results were obtained to classify the product and are not intended to be used for engineering design properties.

## Performance requirements

This PDF is an alternative version. This document was published on 2022-05-26 and may not be the latest version of this evaluation. Users should consult the latest [published assessment](#) on the [CCMC Registry of Product Assessments](#), which contains the most up to date information. This PDF is intended for use as a record, not the latest information available.

**Table 2. Test results for performance under both concentrated static loads and impact loads**

Property		Requirement		Result <sup>(1)</sup>	
		Minimum ultimate load (kN)	Maximum deflection under 0.89-kN load (mm)	Ultimate load (kN)	Deflection under 0.89-kN load (mm) <sup>(2)</sup>
Concentrated load	decking at 50°C	2.45	2.0	2.59	10.29
	decking at 20°C	2.45	2.0	6.90	3.71
	decking at -35°C	2.45	2.0	4.30	4.05
Property		Minimum ultimate load following impact load (kN)	Maximum deflection under 0.89-kN load following impact load (mm)	Ultimate load following impact load (kN)	Deflection under 0.89-kN load following impact load (mm)
Impact load of 102 N·m	decking at 50°C	1.78	2.0	1.78	7.63 <sup>(3)</sup>

**Notes**

- <sup>1</sup> Test results for planks with supports at 400 mm o.c.
- <sup>2</sup> The deflection results exceed the requirements. The additional deflection will not impact the overall performance.
- <sup>3</sup> Deemed acceptable. Although this result (7.63 mm) exceeds the 2.0 mm requirement, the additional deflection is not considered significant for material at 50°C. No failure after impact load and recovery was greater than 96%.

**Table 3. Test results for durability**

Property	Requirement	Result	
		S-P-F lumber	AZEK Deck board
<b>Bending stiffness</b>	Mean percentage loss in bending modulus of elasticity (MOE) after UV exposure <sup>(1)</sup> and accelerated aging <sup>(2)</sup> must be less than or equal to spruce lumber.	23.0%	Pass
<b>Bending strength</b>	Mean percentage loss in bending stress modulus of rupture (MOR) after UV exposure <sup>(1)</sup> and accelerated aging <sup>(2)</sup> must be less than or equal to spruce lumber.	28.3%	Pass

**Notes**

This PDF is an alternative version. This document was published on 2022-05-26 and may not be the latest version of this evaluation. Users should consult the latest [published assessment](#) on the [CCMC Registry of Product Assessments](#), which contains the most up to date information. This PDF is intended for use as a record, not the latest information available.

- 
- 1 4 500 hours of Xenon-Arc exposure following Cycle 1 of ASTM D 2565-99, “Standard Practice for Xenon-Arc Exposure of Plastics Intended for Outdoor Applications.”
  - 2 Five cycles of accelerated aging (wetting, freezing, thawing and drying).
- 

**Table 4. Test results for termite resistance**

Property	Requirement	Result
Termite resistance	Rating must be equal to or better than preservative-treated wood conforming to CAN/CSA-O80.1.	Pass

**Table 5. Test results for performance under concentrated static load – stair tread**

Property		Requirement		Result <sup>(1)</sup>
		Minimum ultimate load (kN)	Minimum ultimate load (kN)	Deflection under 1 kN (mm)
Concentrated load	stair tread	1 <sup>(2)</sup>	0.75	1.33 <sup>(3)</sup>
	stair tread nosing	1 <sup>(4)</sup>		1.64

---

**Notes**

- 1 Test results are for stair stringers spaced at 230 mm o.c. at a test condition of 50°C and 80% RH. Three specimens were tested for each test.
  - 2 Applied through a 75-mm-diameter disk positioned at the centre line of the plank and midway between stringers.
  - 3 Deemed acceptable as the deflection is still very low at 50°C.
  - 4 Applied through a 38-mm-diameter disk positioned along the outside edge of the nosing at the stringer location.
- 

**Additional performance data**

Data in this section does not form part of CCMC’s opinion in Section 1.

**Table 6. Test results for additional performance data <sup>(1)</sup>**

Property		Unit	Reference value	Result
Dimensional tolerances	width	mm	–	140
	thickness	mm	–	25
Density		kg/m <sup>3</sup>	–	661
Hardness (11.28-mm-diameter ball)		kN	≥ 1.8	659
Slip resistance (longitudinal)	dry condition	–	≥ 0.5	0.28 <sup>(2)</sup>
	wet condition			0.59

**Notes**

- <sup>1</sup> Results provided in the table above do not invalidate CCMC's opinion concerning the product's compliance with the NBC 2010.
- <sup>2</sup> Having fallen to 0.28 under the dry condition, no surface finishes met the 0.5 criterion. This criterion may not meet all occupant expectations. The manufacturer may be contacted for further information.



# Administrative information

## Disclaimer

This evaluation is issued by the Canadian Construction Materials Centre (CCMC), a part of the Construction Research Centre at the National Research Council of Canada (NRC). The evaluation must be read in the context of the entire [CCMC Registry of Product Assessments](#) and the legislated applicable building code in effect.

The CCMC was established in 1988 on behalf of the applicable regulator (i.e., the provinces and territories) to ensure—through assessment—conformity of alternative and acceptable solutions to regional building codes as determined by the local authority having jurisdiction (AHJ) as part of the issuance of a building permit. It is the responsibility of the local AHJs, design professionals, and specifiers to confirm that the evaluation is current and has not been withdrawn or superseded by a later issue. Please refer to [the website](#) or contact:

### Canadian Construction Materials Centre

Construction Research Centre  
National Research Council of Canada  
1200 Montreal Road  
Ottawa, Ontario, K1A 0R6  
Telephone: 613-993-6189  
Fax: 613-952-0268

The NRC has evaluated the material, product, system or service described herein only for those characteristics stated herein. The information and opinions in this evaluation are directed to those who have the appropriate degree of experience to use and apply its contents (i.e., AHJs, design professionals and specifiers). This evaluation is only valid when the product is installed in strict compliance with the stated conditions and limitations of evaluation and the applicable local building code. In circumstances where no applicable local building permit is issued and that no confirmation of compliance 'for use in the intended field application' is undertaken, this evaluation is null and void in all respects. This evaluation is provided without representation, warranty, or guarantee of any kind, expressed, or implied, and the NRC provides no endorsement for any evaluated material, product, system or service described herein. The NRC accepts no responsibility whatsoever arising in any way from any and all use and reliance on the information contained in this evaluation with respect to its compliance to the referenced code(s) and standard(s). The NRC is not undertaking to render professional or other services on behalf of any person or entity nor to perform any duty owed by any person or entity to another person or entity.

## Language

Une version française de ce document est disponible.

In the case of any discrepancy between the English and French version of this document, the English version shall prevail.

## Copyright

© 2022 Her Majesty the Queen in Right of Canada, as represented by the National Research Council of Canada.

All rights reserved. No part of this publication may be reproduced, stored in a retrieval system, or transmitted in any form or by any means, electronic, mechanical, photocopying, recording or otherwise, without the prior written permission of the CCMC.

---

**This PDF is an alternative version.** This document was published on 2022-05-26 and may not be the latest version of this evaluation. Users should consult the latest [published assessment](#) on the [CCMC Registry of Product Assessments](#), which contains the most up to date information. This PDF is intended for use as a record, not the latest information available.

## CCMC recognition

The Canadian Construction Materials Centre (CCMC) assesses compliance with Canadian building, energy and safety codes. We are the only construction code compliance service supported and operated by the Government of Canada. Trusted by over 6,000 regulators across Canada.

Most Canadian authorities having jurisdiction (AHJs) consider CCMC product assessments acceptable as evidence for product approval.

### CCMC assessments are recognized by construction authorities across Canada:

Alliance of Canadian Building Official Associations (ACBOA)



[\(Alliance of Canadian Building Official Associations \(ACBOA\)\)](#)

First Nations National Building Officers Association (FNNBOA)



[\(First Nations National Building Officers Association \(FNNBOA\)\)](#)

Canadian Home Builders' Association (CHBA)



[\(Canadian Home Builders' Association \(CHBA\)\)](#)

Alberta Building Officials Association (ABOA)



[\(Alberta Building Officials Associations \(ABOA\)\)](#)

Saskatchewan Building Officials Association (SBOA)



[\(Saskatchewan Building Officials Association \(SBOA\)\)](#)

Manitoba Building Officials Association (MBOA)



[\(Manitoba Building Officials Association \(MBOA\)\)](#)

Ontario Building Officials Association (OBOA)



[\(Ontario Building Officials Association \(OBOA\)\)](#)

New Brunswick Building Officials Association (NBBOA)



[\(New Brunswick Building Officials Association \(NBBOA\)\)](#)

Nova Scotia Building Officials Association (NSBOA)



[\(Nova Scotia Building Officials Association \(NSBOA\)\)](#)

The CCMC provides code compliance assessments to Canadian code requirements, consulting nationwide with construction regulators to elicit regional variations in code requirements as well as provincial and local interpretations. Users are advised to review the technical information presented in CCMC assessments when making approval decisions. [Learn more about how the CCMC provides a unique service for Canada.](#)

For more information, contact the CCMC by phone at (613) 993-6189 or by email at [ccmc@nrc-cnrc.gc.ca](mailto:ccmc@nrc-cnrc.gc.ca)

## Code compliance as an acceptable solution

### Code Compliance via Acceptable Solutions

If a building design (e.g. material, component, assembly or system) can be shown to meet all provisions of the applicable **acceptable solutions** in Division B (e.g. it complies with the applicable provisions of a referenced standard), it is deemed to have satisfied the objectives and functional statements linked to those provisions and thus to have complied with that part of the Code.

— National Building Code of Canada, Sentence A-1.2.1.1.(1)(a)

The CCMC has determined that compliance with this provision of the Code has been demonstrated as an **Acceptable Solution**. The evaluation report provides a summary of the basis of CCMC's compliance opinion.

### CCMC's code compliance opinions

All CCMC evaluation reports are opinions of code compliance established in accordance with the National Building Code of Canada, Subsection 1.2.1. "Compliance with this Code," which requires compliance to be achieved by:

- complying with the applicable acceptable solutions in Division B, or
- using an alternative solution that will achieve at least the minimum level of performance required by Division B in the areas defined by the objective and functional statements attributed to the applicable acceptable solutions.

The CCMC assesses compliance with Canadian building, energy and safety codes, and is trusted by over 6,000 regulators across Canada.

# Code compliance as an alternative solution

## Code Compliance via Alternative Solutions

Where a design differs from the acceptable solutions in Division B, then it should be treated as an **"alternative solution."** A proponent of an alternative solution must demonstrate that the alternative solution addresses the same issues as the applicable acceptable solutions in Division B and their attributed objectives and functional statements. However, because the objectives and functional statements are entirely qualitative, demonstrating compliance with them in isolation is not possible. Therefore, Clause 1.2.1.1.(1)(b) identifies the principle that Division B establishes the quantitative performance targets that alternative solutions must meet. In many cases, these targets are not defined very precisely by the acceptable solutions [...] Nevertheless, Clause 1.2.1.1.(1)(b) makes it clear that an effort must be made to demonstrate that an alternative solution will perform as well as a design that would satisfy the applicable acceptable solutions in Division B—not “well enough” but “as well as.”

— National Building Code of Canada, Sentence A-1.2.1.1.(1)(b)

The CCMC has determined that compliance with this provision of the Code has been demonstrated as an **Alternative Solution**. The evaluation report provides a summary of the basis of CCMC's compliance opinion.

### CCMC's code compliance opinions

All CCMC evaluation reports are opinions of code compliance established in accordance with the National Building Code of Canada, Subsection 1.2.1. "Compliance with this Code," which requires compliance to be achieved by:

- complying with the applicable acceptable solutions in Division B, or
- using an alternative solution that will achieve at least the minimum level of performance required by Division B in the areas defined by the objective and functional statements attributed to the applicable acceptable solutions.

The CCMC assesses compliance with Canadian building, energy and safety codes, and is trusted by over 6,000 regulators across Canada.